

Esquema de ligação do T31A ou T34A

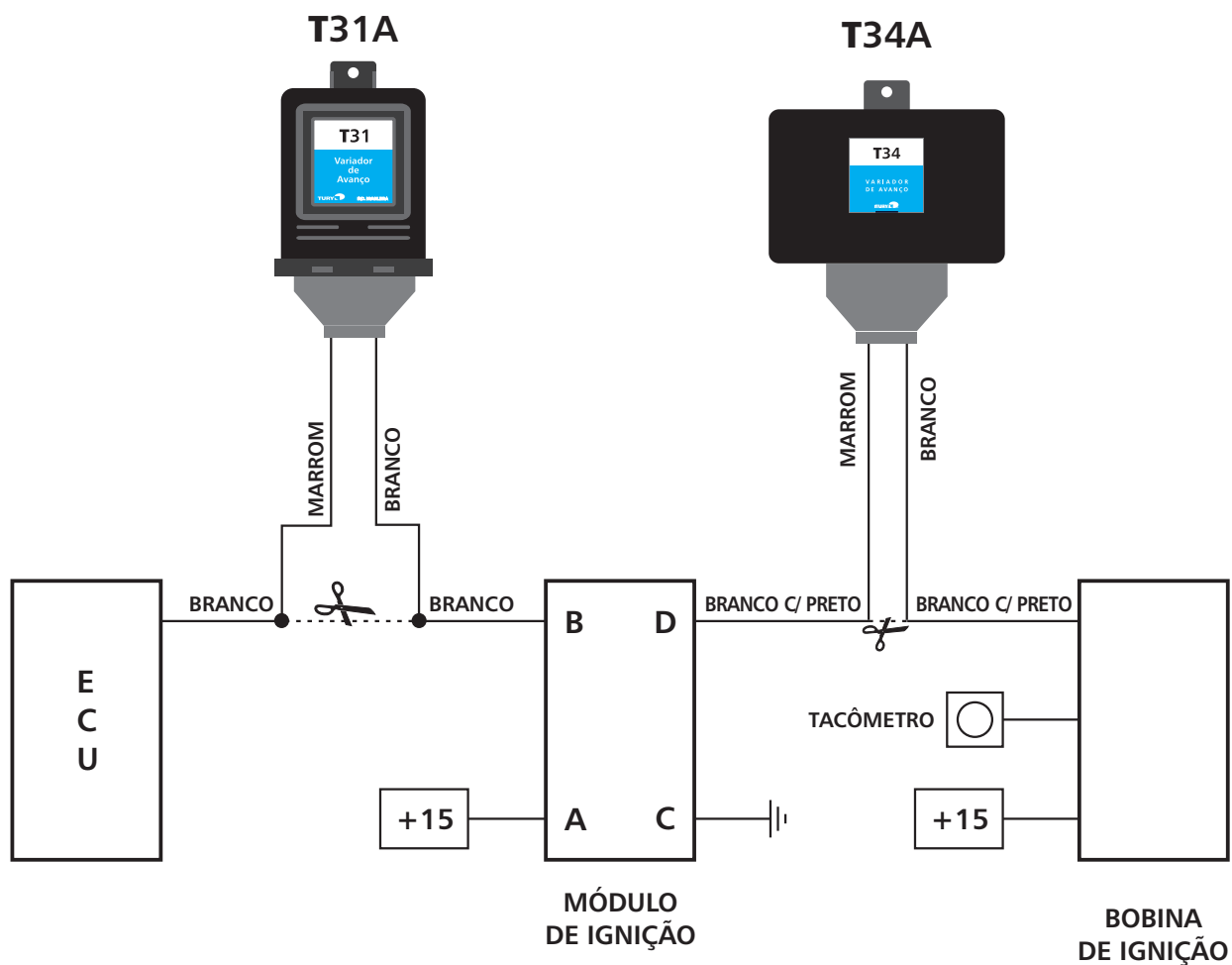

Obs.: No conector do módulo de ignição, observar as letras e seguir o esquema de ligação.

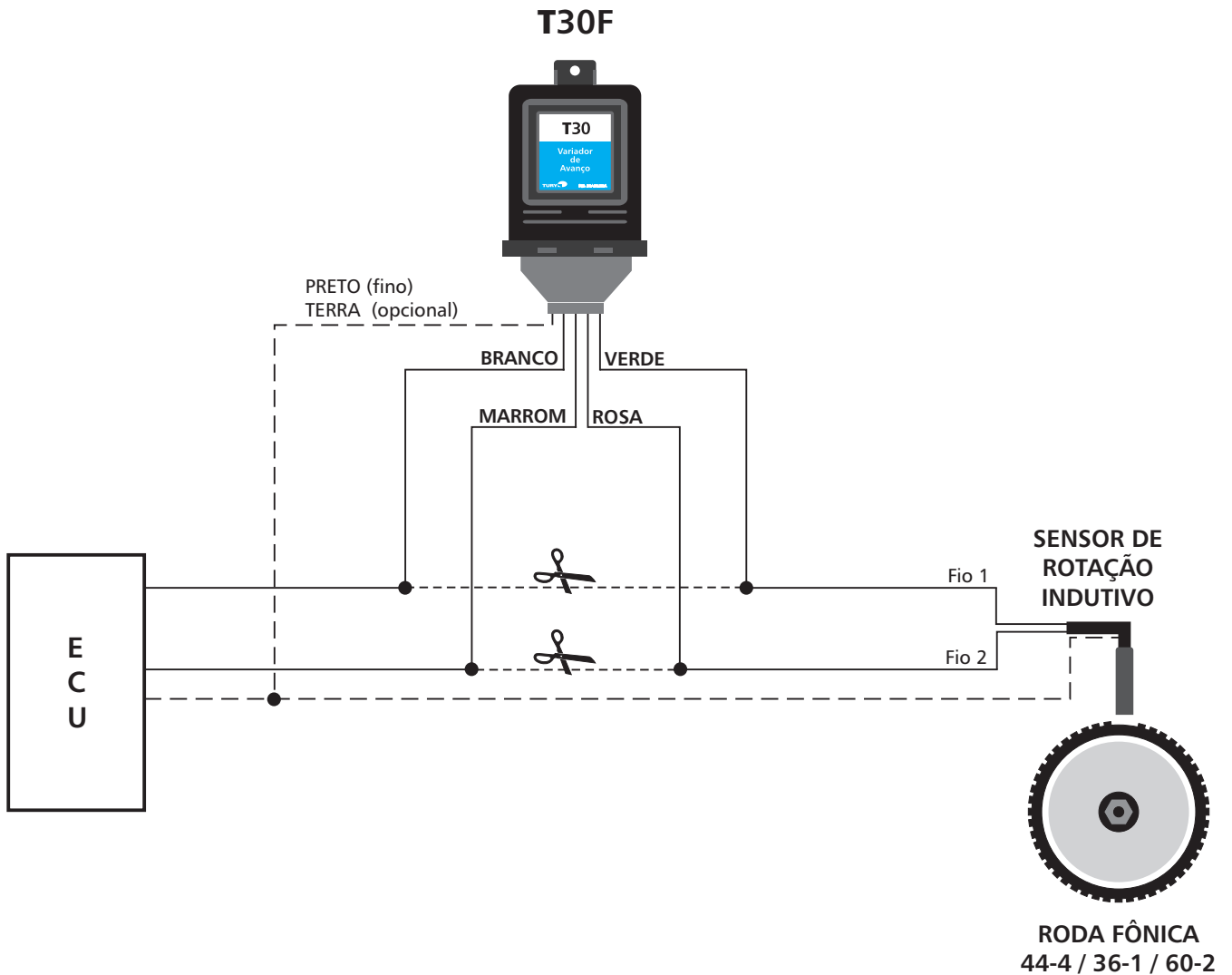

CORES DOS FIOS NOS CARROS

| Marca / Veículo | Fio 1 | Fio 2 |
|---|--------------------|---------------------|
| Fiat-Marea 2.4 20V | Amarelo | Azul |
| Fiat-Motores Fire/Flex 1.0,1.3 e 1.4 8V/16V - M.Marelli | Branco (pino 42LM) | Vermelho (pino10LM) |
| Fiat-Motores Fire/Flex 1.0,1.3 e 1.4 8V/16V - Bosch | Vermelho | Branco |
| Ford-EcoSport / Focus 2.0 | Branco/Vermelho | Marrom/Vermelho |
| Ford-F250, Explorer, Ranger e Taurus V6 24V | Azul (pino 21) | Cinza (pino 22) |
| GM-Blazer e S10 2.2, Omega 4.1 | Amarelo | Preto |
| GM-Omega / Suprema 2.2 e Corsa | Cinza/Preto | Cinza/Vermelho |
| Mercedes- Classe A 160 / 190 | Pino 9 | pino 10 |
| Toyota- Corolla / Fielder VVT-i 1.8 / 2.0 16V | Branco | Preto |
| VW-Passat / Variant 1.8 20V | Branco (pino 56) | Azul (pino 63) |
| VW-Passat / Variant 2.8 30V V6 | Cinza (pino 56) | Azul (pino 63) |

Esquema de ligação do T36A

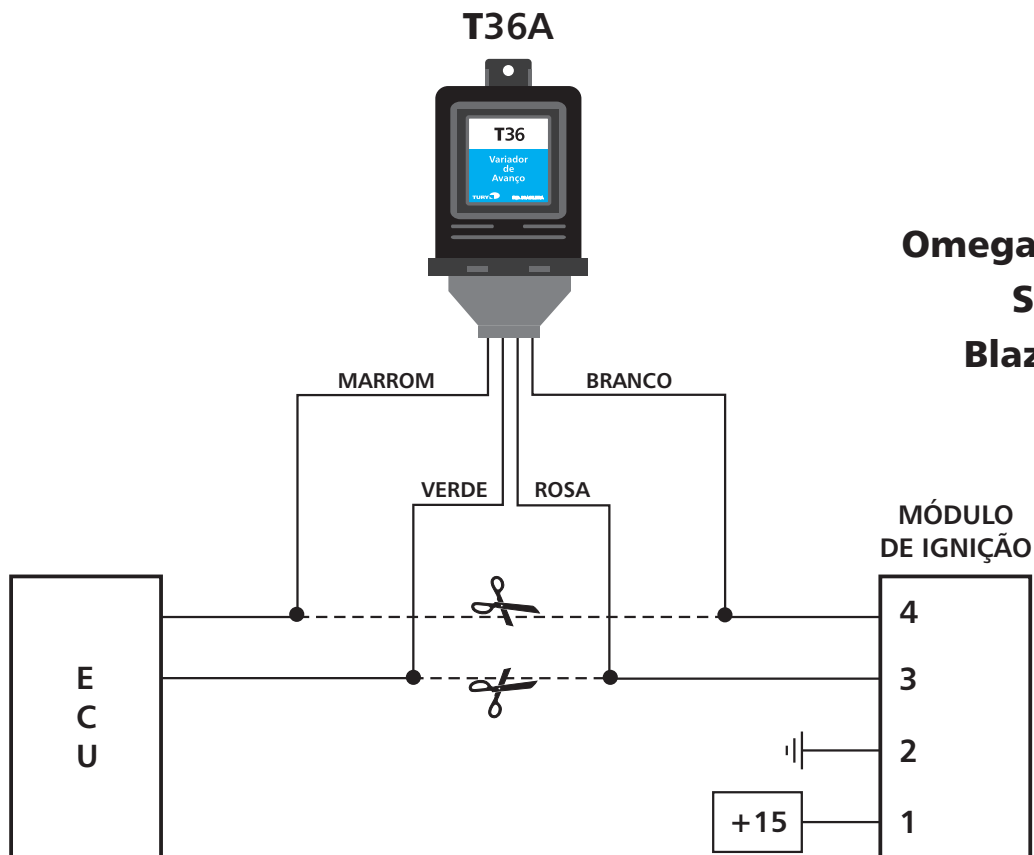
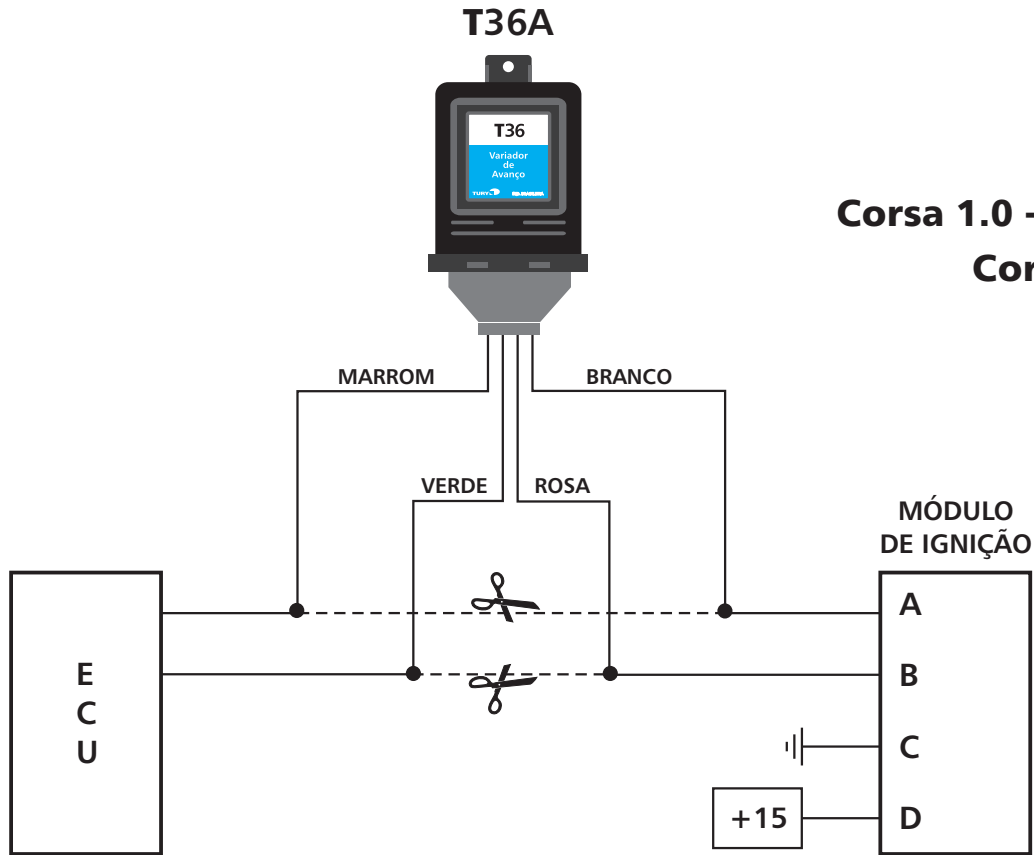

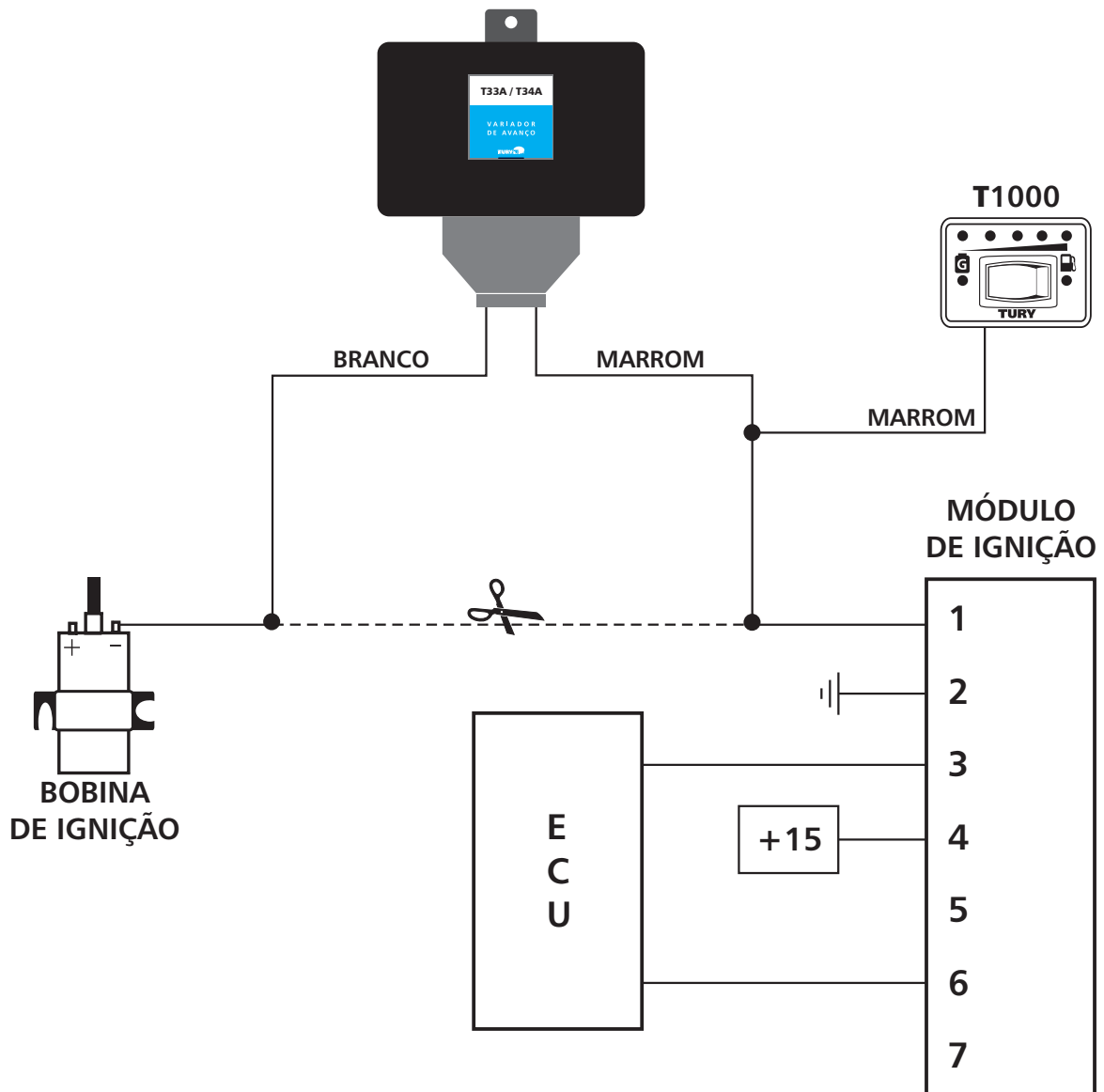

Esquema de ligação do T33A/T34A

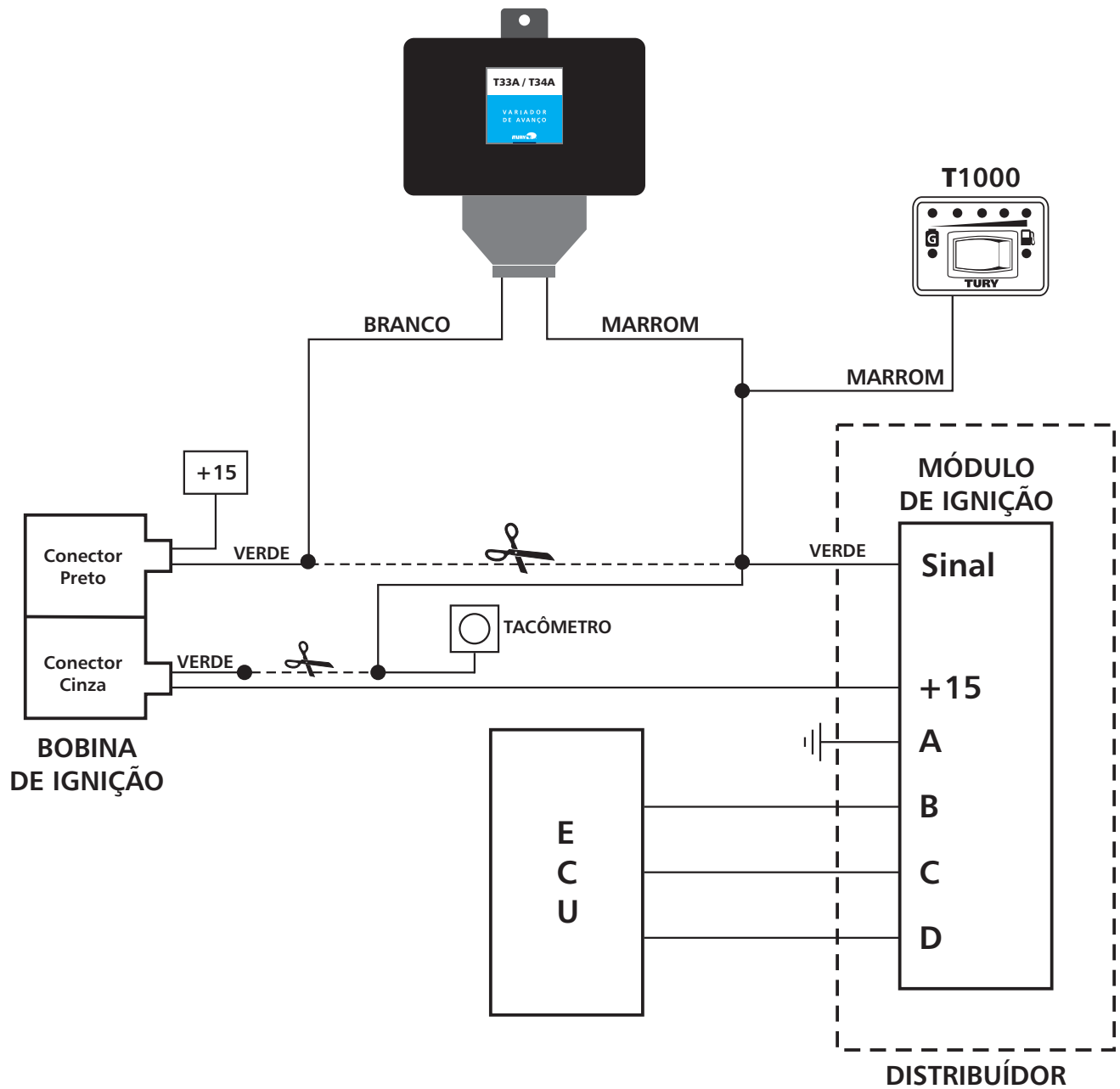

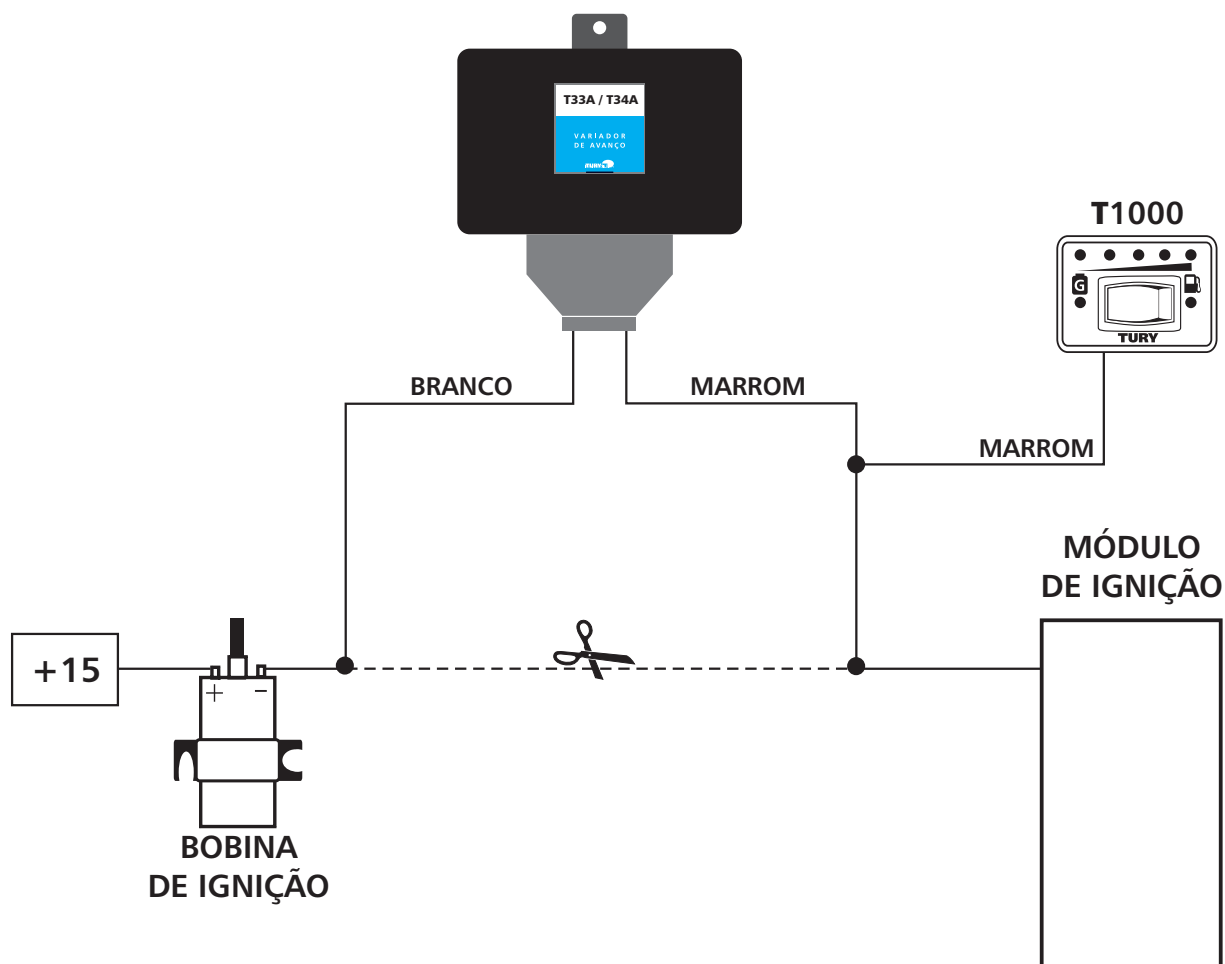

Obs.: desconsiderar fio amarelo (TPS) e desligar a chave 7.

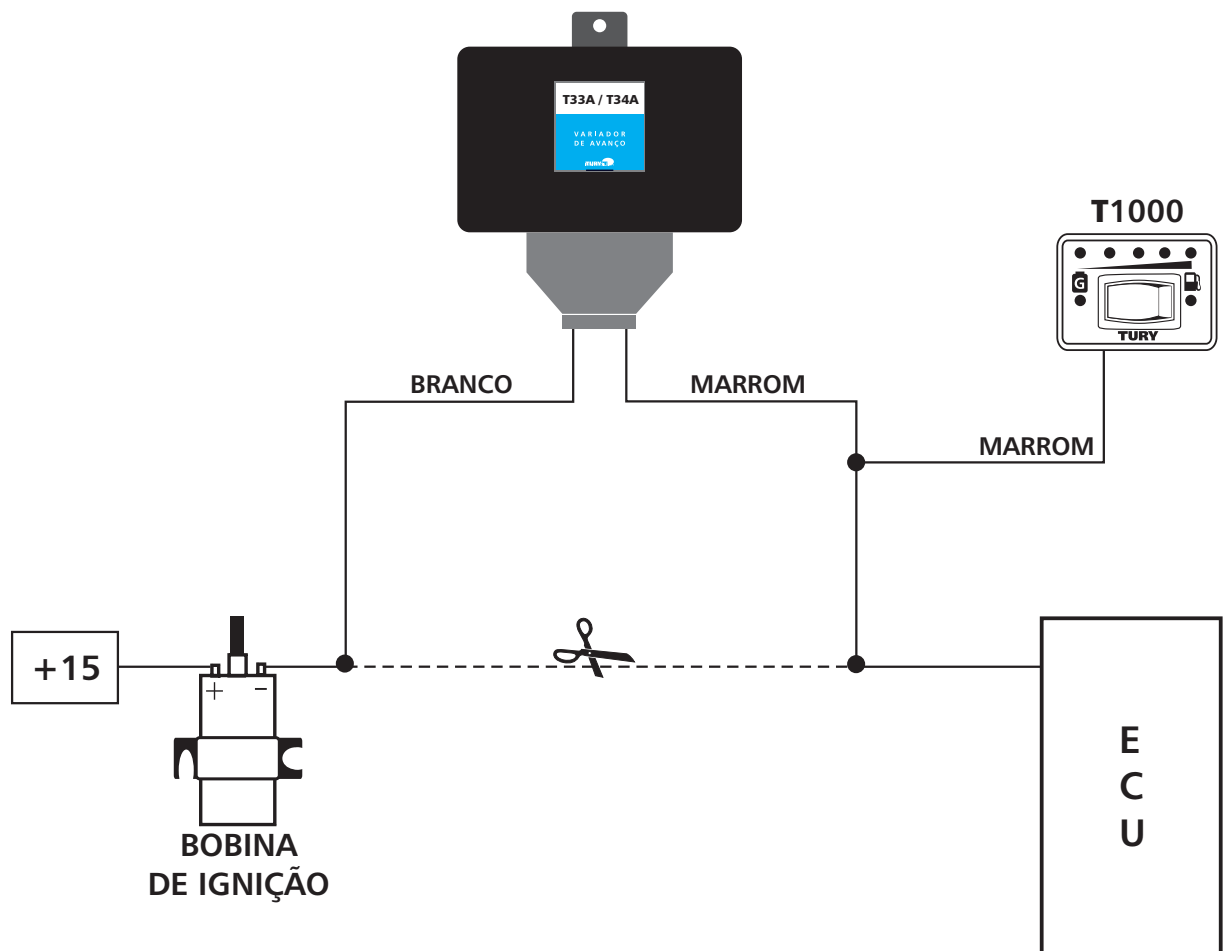

Esquema de ligação do T31C

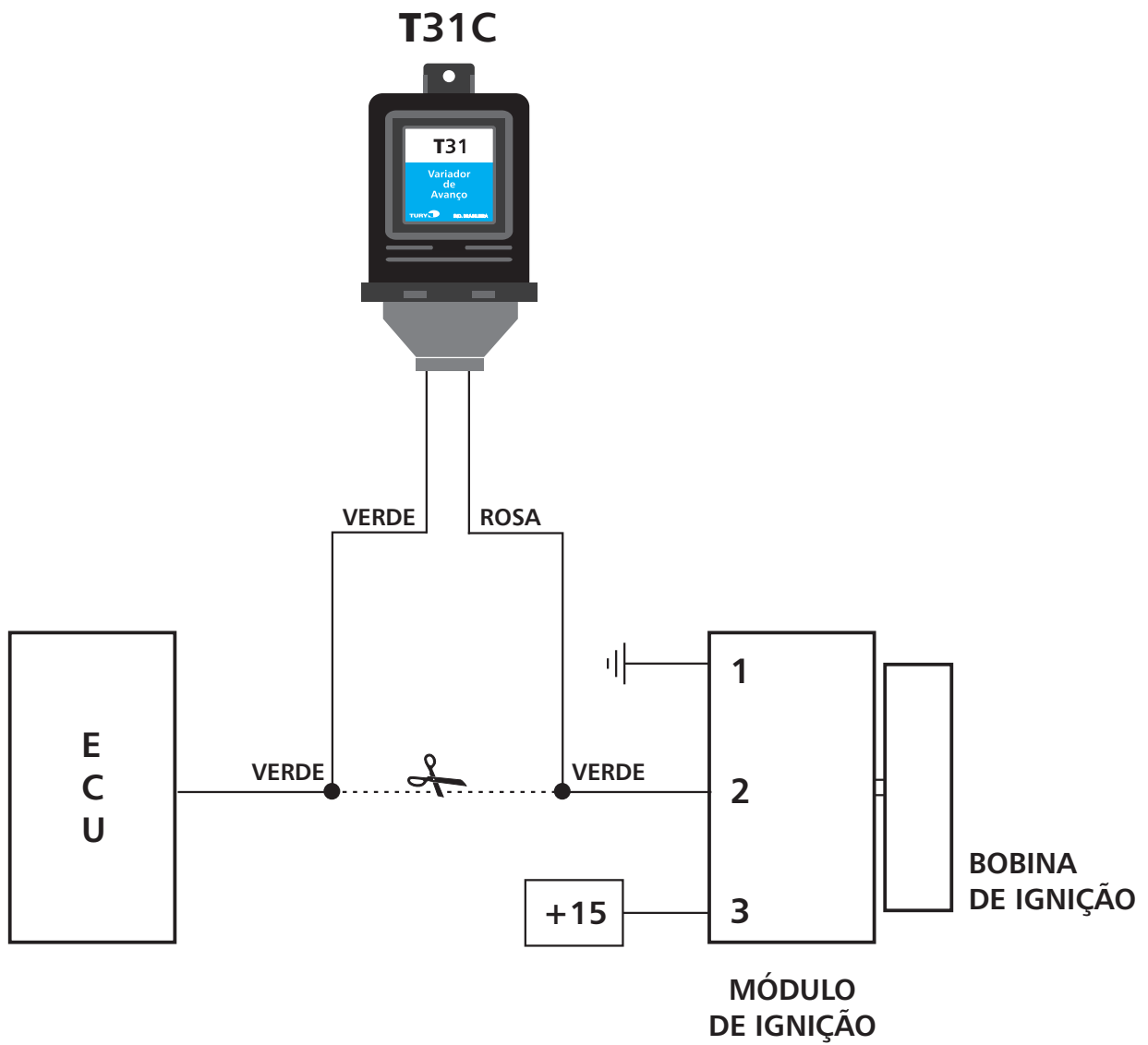

**Esquema de ligação para sistemas de ignição híbrido
(Módulo de ignição com bobina de ignição incorporada)**

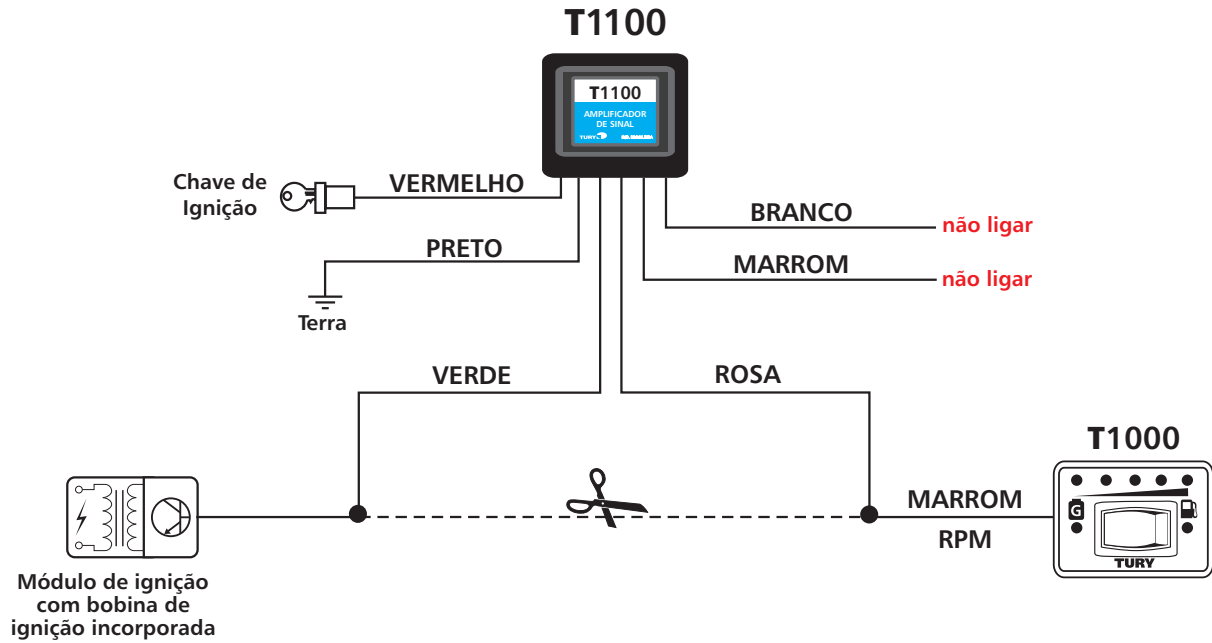

Esquema de ligação para sistemas de ignição simples

